

FLOCKING OBJECTS

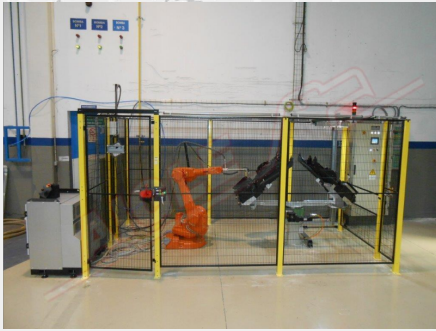

PLASMA TREATMENT BOOTH MOD. CP/R



The CP/R Atmospheric Plasma Treatment Cabin consists of:

- Enclosed cabin with safety guards
- Plasma unit
- Robot
- Interior light (2 x 18W)
- Control cabin



The booth can handle a wide variety of objects of different shapes. The process is fully automatic and is carried out by means of a robot. The workpieces to be treated are placed on a rotating table; the operator places the object there and the table rotates, bringing it to the automatic plasma treatment position; in the other position, the workpiece is ready for the loading/unloading operation.

TECHNICAL DATA

Power supply	400 V/50 Hz/three-phase
Installed power	3 kW

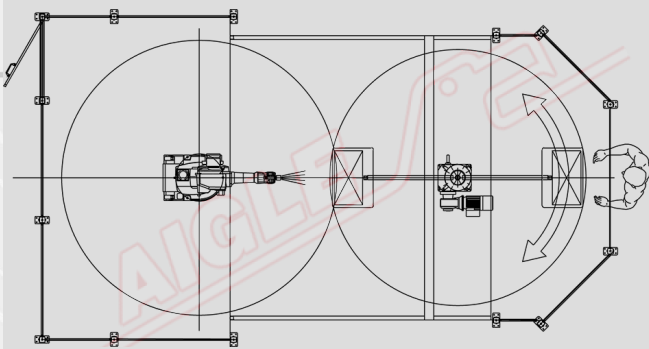

Member of CISQ Federation

