

FLOCKING FABRICS AND ROLL MATERIALS

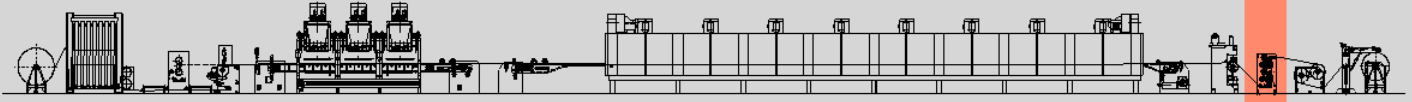

Brushing Unit - mod. SZ2



The **Brushing Unit mod. SZ2** consists of:

- Two rotating brushes with a "beater-bar" effect that is opposed to the flocked fabric and with adjustable pressure. Brushes are sealed inside the suction chambers, in order to avoid flock dispersion.
- Two A.C. motors with a system of belts and pulleys for brush rotation.
- A flock recovery system equipped with sleeve filters and a suction fan connected to the brushes chambers.

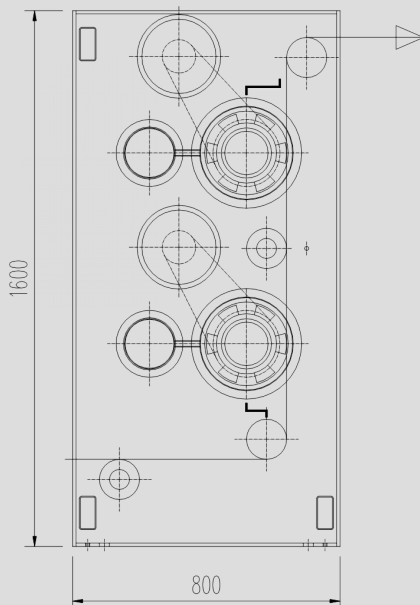

TECHNICAL DATA

Useful width	to be defined
Mechanical speed	40 m/min. max.
Power supply	400 V/50 Hz/three-phase
Installed power	4 kW

Member of CISQ Federation



AIGLE