

PROFILES FLOCKING LINE

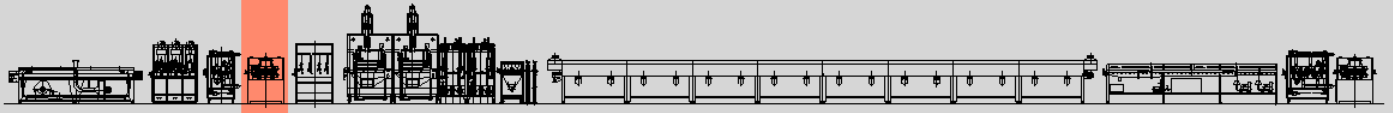

Caterpillar - mod. CTP800

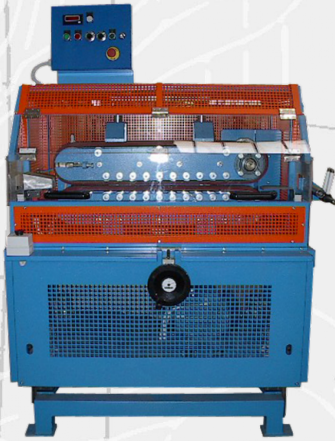

The **Caterpillar mod. CTP800** consists of a strong, motorized frame installed in the lower part, and a couple of opposed 10 mm rubber covered "Poly V" belts, installed in the upper part.

Drive transmission is obtained with a special "Schmidt" joint.

A double row of grooved rollers inside the belts grants total and constant pressure all along.

For safety reasons, at machine stopping and/or at door opening, a pneumatic piston automatically lifts the upper belt 100 mm upwards, allowing for comfortable profile access and easy machine inspection.

Contact pressure between belts on the profile is obtained through a retractable cylinder and adjusted using a handwheel equipped with a gravimetric index.

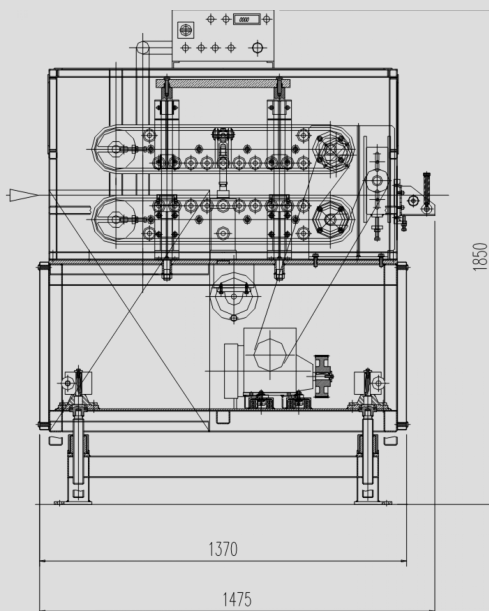

TECHNICAL DATA

Belt width	100 mm
Useful belt contact length	800 mm
Motorization	3 kW
Power supply	400 V/50 Hz/three-phase
Installed power	4 kW
Compressed air	7±1 Kg/cm ²

Member of CISQ Federation



CERTIFIED MANAGEMENT SYSTEM
ISO 9001 - ISO 14001



SUSTAINABLE MACHINERY CERTIFICATION

AIGLE