

# LAMINATING

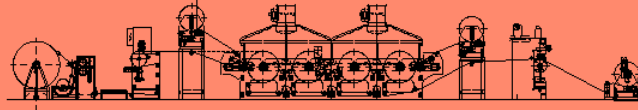

## Laminating Group - mod. GRA/1



The **Laminating Group mod. GRA/1** is for wet lamination and dry-coat lamination technology. It consists of:

- Upper unwinding unit with aligning system of the fabric to be laminated with fabric unwinding position with couples of beam-holder self-closing chucks and manual brake
- Enlarging cylinder
- Laminating cylinder, hard chrome plated and ground. It is mounted on vertical slides, it is provided with micrometric adjustment of the working layer and actuated by two pneumatic cylinders for a quick lifting
- Laminating cylinder, rubber covered and ground
- Both laminating cylinders are motorized in synchronisation with the rest of the line

Options: the laminating cylinder can be heated by diathermic oil or cooled by water according to the technological needs.

A.C. Motorization and Control Panels mod. QE.

### TECHNICAL DATA

Power supply	400 V/50 Hz/three-phase
Installed power	3 kW
Compressed air	7±1 Kg/cm <sup>2</sup>

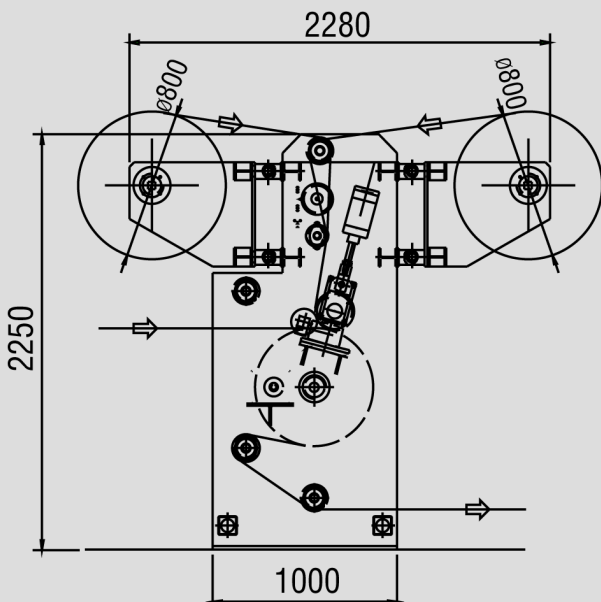

Member of CISQ Federation



# AIGLE