

FLOCKING FABRICS AND ROLL MATERIALS

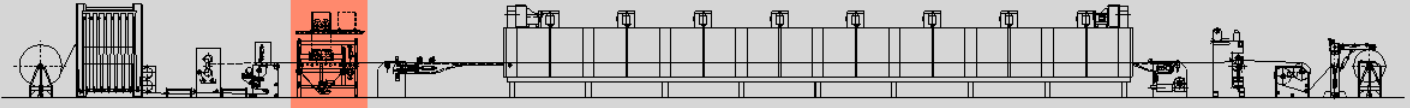

Flocking Machine - mod. FR2

The **Flocking Machine mod. FR2** consists of:

- Two electrostatic hoppers with two multi-row rotating brushes. Each brush is opposed to a stainless steel screen. Rotation speed and pressure are both adjustable and the screen can easily be removed
- A lifting system to adjust the gap between the hoppers and the fabric
- A set of beater bars rotating at high speeds (can be varied). A collector below the beater bars recovers flock which falls off the fabric. The collector is equipped with a screw conveyor which connects it to the suction system
- Sealing of the flocking area with aluminium and glass windows, in order to prevent flock dispersion. When the windows are opened, the electrostatic field is automatically disconnected
- An electrostatic Generator
- A pre-feeder placed on top of the machine, which stores flock and constantly feeds it to the flocking hoppers. Flock level inside each flocking hopper is controlled automatically.

The **flocking machine mod. FR2** main features are:

- Hoppers which handle flock very carefully, thus preventing the accumulation and formation of flock balls
- Uniform, constant and accurate flock distribution, both along the width and length of the fabric
- Electronic controls to maintain a constant level of flock inside the hoppers
- Light-weight and balanced beater bars, built with special hexagonal aluminium sections exclusively designed by **AIGLE**, in order to ensure maximum uniformity of fabric vibration



Member of CISQ Federation



AIGLE

FLOCKING FABRICS AND ROLL MATERIALS

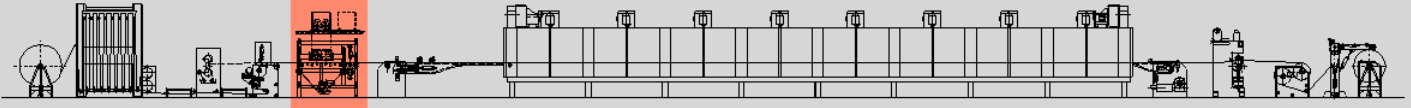

- A pre-cleaning suction blade to remove excess flock from the fabric

- Easy access in order to reduce the time required for colour change

- High insulation factor in order to avoid dispersion of the electrostatic field

- Maximum penetration of flock into the adhesive, due to the power of the generators employed and the quality of the beater bars. As an exclusive result, the finished product will be highly resistant to washing and abrasion.

The Flocking machines of the FR series can also be equipped with automatic systems for the recovery of the clumps of flock: special nozzles recover any impurities within the hoppers by putting them through an appropriate sieve.

Furthermore, the FR flocking machines series can be customized according to specific production requirements.

Finally, these machines ensure high quality standards for:

- flocked products
- repeatability of the flocked product
- reliability of the machines
- easy and quick maintenance
- easy and quick to clean
- operator's safety

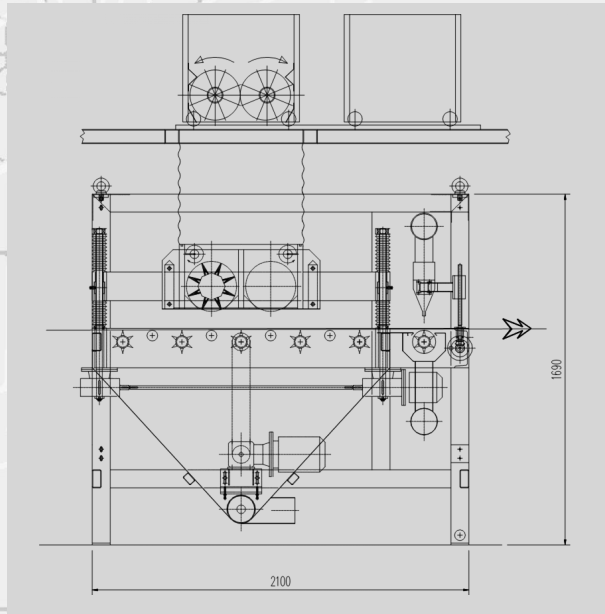

TECHNICAL DATA

Power supply	400 V/50 Hz/three-phase
Installed power	25 kW
Compressed air	7±1 Kg/cm ²
Useful width	to be defined

Member of CISQ Federation

